



—Mocenigo  
Suspension 400/21 K CR

## \_Mocenigo

Design Aldo Bruno Maria Teardo  
e Arianna Teardo

— Una composizione di voluttuosi nastri di vetro e trame fantasiose che donano dinamismo a una collezione capace di caratterizzare gli ambienti con un senso di serena leggerezza. Il motivo a losanghe delle superfici è ottenuto imprimendo il pattern sul vetro a caldo. La luce percorre le linee curve, si moltiplica nella trama geometrica e si specchia nei dettagli metallici della struttura creando uno scenografico gioco di riflessioni.

— Mocenigo proposes a gorgeous composition of curved, textured glass ribbons and was designed to create an appealing atmosphere in any room. The diamond effect is achieved by impressing the pattern on the glass while hot ( 'a caldo' technique). The light flows along the lines of the patterned surface, highlighting the metal details of the frame and creating a gorgeous play of shimmering light.





# Mocenigo

## Finitura Metallo / Metal Finishes

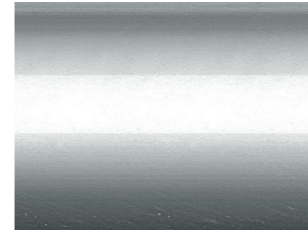

**K**  
Cromo lucido  
Polish chrome

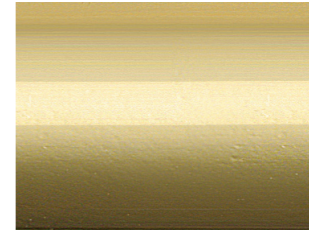

**D**  
Dorato lucido  
Polish gold



**NN**  
Nickel nero  
Black nickel

## Finitura Vetro / Glass Finishes



**AMB**  
Ambra  
Amber

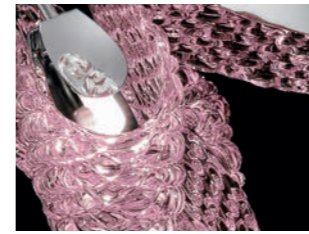

**AMT**  
Ametista  
Amethyst

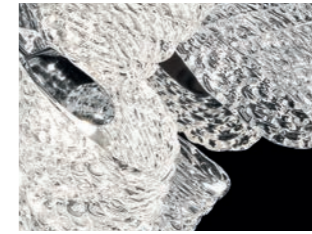

**CR**  
Cristall  
Clear

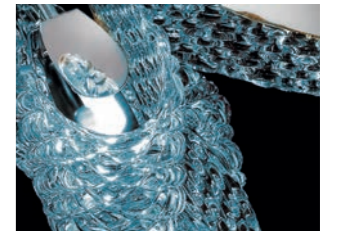

**DEN**  
Denim  
Blue Denim



**FU**  
Fumé  
Smoked



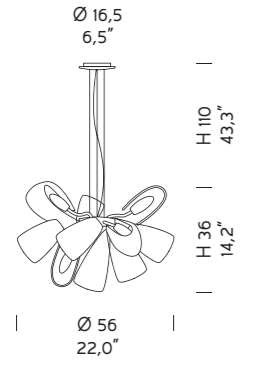

**400/9**  
9 x MAX 40W G9

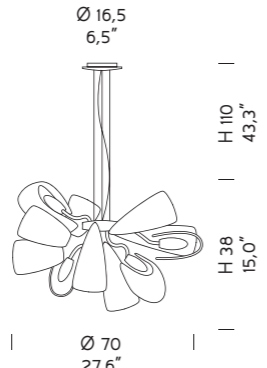

**400/12**  
12 x MAX 40W G9

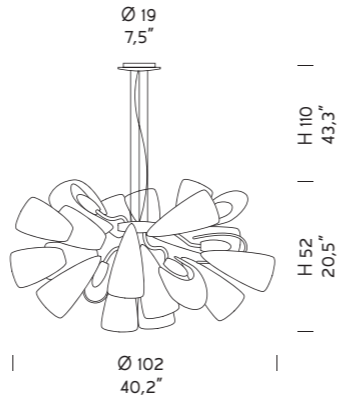

**400/21**  
21 x MAX 40W G9

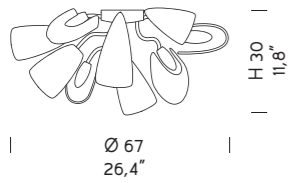

**401/9**  
9 x MAX 40W G9

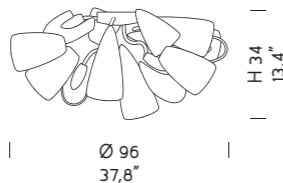

**401/15**  
15 x MAX 40W G9

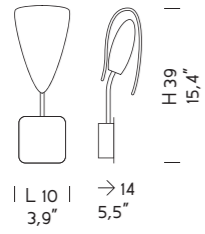

**402/A1**  
1 x MAX 40W G9

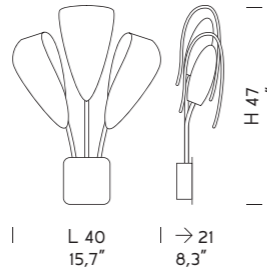

**402/A3**  
3 x MAX 40W G9

SYLCOM

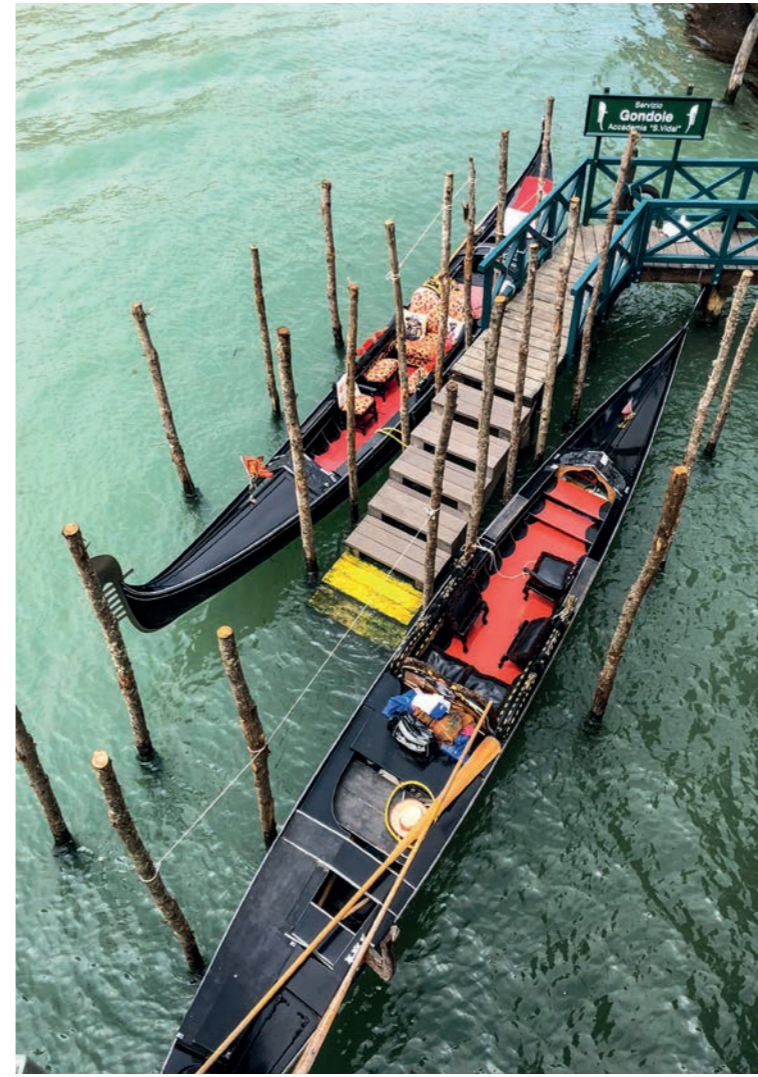

MOCENIGO